



UL INTERNATIONAL (UK) LTD
 Womersley House, Building C,
 The Guildway,
 Old Portsmouth Road,
 Guildford. GU3 1LR.
 United Kingdom.



designated according to Article 29 of the Regulation (EU) No 305/2011 and member of EOTA (European Organisation for Technical Assessment, www.eota.eu)

European Technical Assessment

**ETA 14/0034
of 03/09/2015**

Technical Assessment Body issuing the ETA and designated according to Article 29 of the Regulation (EU) No 305/2011: UL International (UK) Ltd

Trade name of the construction product

Graft FR Board

Product family to which the construction product belongs

Fire Stopping and Sealing Product:
 • Penetration Seals

Manufacturer

Polyseam AS
 Ravneveien 7
 Linnestad Næringsområde
 N-3174 Revetal, Norway
<http://www.polyseam.com>

Manufacturing plant(s)

Polyseam Ltd
 Shaw Park
 Silver Street
 Huddersfield, West Yorkshire
 HD5 9AF, UK

This European Technical Assessment contains

39 pages including 1 Annex which forms an integral part of this assessment.

This European Technical Assessment is issued in accordance with regulation (EU) No 305/2011, on the basis of

ETAG 026-2, edition 2011, used as European Assessment Document (EAD).

This version replaces

ETA 14/0034 issued on 21/02/2014

Translations of this European Technical Assessment in other languages shall fully correspond to the original issued document and should be identified as such.

Communication of this European Technical Assessment, including transmission by electronic means, shall be in full. However, partial reproduction may be made, with the written consent of the issuing Technical Assessment Body. Any partial reproduction has to be identified as such.

Table of Contents

I.	SPECIFIC PARTS OF THE EUROPEAN TECHNICAL ASSESSMENT	3
1	Technical description of the product	3
2	Specification of the intended uses of the product in accordance with the applicable European Assessment Document (Hereinafter EAD): ETAG 026-2	3
3	Performance of the product and references to the methods used for its assessment	5
4	ASSESSMENT AND VERIFICATION OF CONSTANCY OF PERFORMANCE (HEREINAFTER AVCP) SYSTEM APPLIED, WITH REFERENCE TO ITS LEGAL BASE	6
5	Technical details necessary for the implementation of the AVCP system, as provided for in the applicable EAD	6
6	Issued on:	7
	ANNEX A – Resistance to Fire Classification – Graft FR Board	8
A.1	Rigid wall constructions according to 1.2.1 with wall thickness of minimum 150 mm	8
A.1.1	Cable penetration seal with 2x 60 mm thick Graft FR Board 2-S	8
A.1.2	Cable penetration seal with 1x 60 mm thick Graft FR Board 2-S	10
A.1.3	Pipe penetration seal with 2x 60 mm thick Graft FR Board 2-S	11
A.1.4	Pipe penetration seal with 1x 60 mm thick Graft FR Board 2-S	13
A.1.5	Pipe penetration seal with 1x Graft FR Board 2-S	16
A.1.6	Graft FR Board 60 mm 2-S penetration seal (protruding) blank and with cables, in rigid wall min. 150 mm thick	17
A.1.7	FR Board 60 mm 2-S penetration seal (pattress) blank and with cables, in rigid wall min. 150 mm thick	18
A.2	Rigid floor constructions according to 1.2.1 with floor thickness of minimum 150 mm	19
A.2.1	Cable penetration seal with 2x Graft FR Board 2-S	19
A.2.2	Cable penetration seal with 1x Graft FR Board 2-S	20
A.2.3	Pipe penetration seal with 2x Graft FR Board 2-S	21
A.2.4	Pipe penetration seal with 1x Graft FR Board 2-S	23
A.2.5	Pipe penetration seal with 1x Graft FR Board 2-S	26
A.2.6	Pipe penetration seal with 1x Graft FR Board 2-S	27
A.2.7	Pipe penetration seal with 2x Graft FR Board 2-S	28
A.2.8	Pipe penetration seal with 2x Graft FR Board 2-S (back to back)	29
A.3	Flexible wall constructions according to 1.2.1 with wall thickness of minimum 100 mm	31
A.3.1	Cable penetration seal with 2x Graft FR Board 1-S	31
A.3.2	Pipe penetration seal with 2x Graft FR Board 1-S	32
A.3.3	Pipe penetration seal with 2x Graft FR Board 1-S	34
A.3.4	Pipe penetration seal with 2x Graft FR Board 1-S	37
A.3.5	Plastic pipe penetration seal with 2x Graft FR Board 1-S	39

I. SPECIFIC PARTS OF THE EUROPEAN TECHNICAL ASSESSMENT

1 Technical description of the product

- 1) Graft FR Board is a coated mineral wool board used to reinstate the fire resistance performance of wall and floor constructions where they have been provided with apertures for the penetration of single or multiple services.
- 2) The Graft FR Board is supplied coated on one face, referenced 1-S, or on both faces, referenced 2-S. The board or boards are then cut to allow the penetration of the required services, before being inserted into the aperture in the wall.
- 3) Graft FR Pipe Wraps are required to be used in conjunction with Graft FR Board depending upon the required application and classification (see Annex B). Graft FR Pipe Wraps are the subject of a separate ETA which is not declared in the document for confidentiality reasons.
- 4) Polyseam AS submitted a written declaration that Graft FR Board does not contain substances which have to be classified as dangerous according to Directive 67/548/EEC and Regulation (EC) No 1272/2008 and listed in the "Indicative list on dangerous substances" of the EGDS - taking into account the installation conditions of the construction product and the release scenarios resulting from there.

In addition to the specific clauses relating to dangerous substances contained in this European technical Assessment, there may be other requirements applicable to the products falling within its scope (e.g. transposed European legislation and national laws, regulations and administrative provisions). In order to meet the provisions of the Construction Products Regulation, these requirements need also to be complied with, when and where they apply.

2 Specification of the intended uses of the product in accordance with the applicable European Assessment Document (Hereinafter EAD): ETAG 026-2

Detailed information and data is given in Annex A.

- 1) The intended use of Graft FR Board is to reinstate the fire resistance performance of flexible wall, rigid wall and floor constructions where they are penetrated by various cables, metallic pipes, composite pipes and plastic pipes.
- 2) The specific elements of construction that the system Graft FR Board may be used to provide a penetration seal in, are as follows:
 - a. Flexible walls: The wall must have a minimum thickness of 100 mm and comprise steel studs lined on both faces with minimum 2 layers of 12.5 mm thick boards.
 - b. Rigid walls: The wall must have a minimum thickness of 150 mm and comprise concrete, aerated concrete or masonry, with a minimum density of 650 kg/m³.
 - c. Rigid floors: The floor must have a minimum thickness of 150 mm and comprise aerated concrete or concrete with a minimum density of 650 kg/m³.

The supporting construction must be classified in accordance with EN 13501-2 for the required fire resistance period.

- 3) The System Graft FR Board may be used to provide a penetration seal with cables, cable trays, metallic pipes, composite pipes and plastic pipes, with and without insulation (for details see Annex A).
- 4) The total amount of cross sections of services (including insulation) should not exceed 60% of the penetration area.
- 5) The system Graft FR Board may be used to seal apertures in the separating element up to 2400mm wide by 1200mm high in a wall, and 2400mm by 1200 mm in a floor. The minimum permitted separation between adjacent seals/apertures is 200mm. Services should be a minimum of 25mm from seal edges. Services within the system Graft FR Board seal do not require a minimum separation, except pipes where pipe insulation penetrates the seal and plastic pipe penetrations which should be a minimum of 100 mm from other services in the aperture.
- 6) Services in floors shall be supported at 250mm and 400mm from the top face. Services in walls shall be supported at 270mm and 470mm from both faces of the wall.
- 7) The provisions made in this European Technical Assessment are based on an assumed working life of the Graft FR Board of 10 years, provided that the conditions laid down in the product datasheet for the packaging/transport/ storage/installation/use/repair are met. The indications given on the working life cannot be interpreted as a guarantee given by the producer, but are to be regarded only as a means for choosing the right products in relation to the expected economically reasonable working life of the works.
- 8) Type Z₂: Intended for uses in internal conditions with humidity lower than 85 % RH excluding temperatures below 0°C, without exposure to rain or UV.

3 Performance of the product and references to the methods used for its assessment

Product-type: Sealant		Intended use: Penetration Seal	
Basic requirement for construction work	Essential characteristic	Performance	
	Mechanical resistance and stability		
-	None	Not relevant	
Safety in case of fire			
EN 13501-1	Reaction to fire	Class F (untested)	
EN 13501-2	Resistance to fire	Annex A	
Hygiene, health and environment			
EN 1026:2000	Air permeability (material property)	No performance determined	
ETAG 026-2, Annex C	Water permeability (material property)	No performance determined	
Declaration of manufacturer	Release of dangerous substances	Declaration of manufacturer	
Safety in use			
EOTA TR 001:2003	Mechanical resistance and stability	No performance determined	
EOTA TR 001:2003	Resistance to impact/movement	No performance determined	
EOTA TR 001:2003	Adhesion	No performance determined	
Protection against noise			
EN 10140-2/ EN ISO 717-1	Airborne sound insulation	No performance determined	
Energy economy and heat retention			
EN 12664, EN 12667 or EN 12939	Thermal properties	No performance determined	
EN ISO 12572 EN 12086	Water vapour permeability	No performance determined	
General aspects relating to fitness for use			
EN 13162 or EN 14303, EN ISO 1519	Durability and serviceability	Z ₂	

4 ASSESSMENT AND VERIFICATION OF CONSTANCY OF PERFORMANCE (HEREINAFTER AVCP) SYSTEM APPLIED, WITH REFERENCE TO ITS LEGAL BASE

According to the decision 1999/454/EC – Commission Decision of date 22nd June 1999 on on the procedure for attesting the conformity of construction products pursuant to Article 20(2) of Council Directive 89/106/EEC as regards fire stopping, fire sealing and fire protective products, published in the Official Journal of the European Union (OJEU) L178/52 of 14/07/1999, see <http://eur-lex.europa.eu/JOIndex.do>) of the European Commission¹, as amended, the system(s) of assessment and verification of constancy of performance (see Annex V to Regulation (EU) No 305/2011) given in the following table(s) applies (apply).

Product(s)	Intended use(s)	Level(s) or class(es)	System(s)
Fire stopping and Fire Sealing Products	For fire compartmentation and/or fire protection or fire performance	Any	1

5 Technical details necessary for the implementation of the AVCP system, as provided for in the applicable EAD

Tasks of the manufacturer:

Factory production control

The manufacturer shall exercise permanent internal control of production. All the elements, requirements and provisions adopted by the manufacturer shall be documented in a systematic manner in the form of written policies and procedures, including records of results performed. This production control system shall ensure that the product is in conformity with this European technical Assessment.

The manufacturer may only use initial / raw / constituent materials stated in the technical documentation of this European Technical Assessment.

The factory production control shall be in accordance with the Control Plan of 8th April 2013 relating to the European technical assessment ETA 14/0034 issued on 03/09/2015 which is part of the technical documentation of this European technical approval. The "Control Plan" is laid down in the context of the factory production control system operated by the manufacturer and deposited at UL International (UK) Ltd.

The results of factory production control shall be recorded and evaluated in accordance with the provisions of the Control Plan.

¹ Official Journal of the European Communities L178/52 of 14/7/1999

Other tasks of the manufacturer

Additional information

The manufacturer shall provide a technical data sheet and an installation instruction with the following minimum information:

(a) Technical data sheet:

- Field of application:
- Building elements for which the penetration seal is suitable, type and properties of the building elements like minimum thickness, density, and - in case of lightweight constructions – the construction requirements.
- Limits in size, minimum thickness etc. of the penetration seal
- Construction of the penetration seal including the necessary components and additional products (e.g. backfilling material) with clear indication whether they are generic or specific.
- Services which the penetration seal is suitable, type and properties of the services like material, diameter, thickness etc. in case of pipes including insulation materials; necessary/allowed supports/fixings (e.g. cable trays)

(b) Installation instruction:

- Steps to be followed
- Procedure in case of retrofitting
- Stipulations on maintenance, repair and replacement

6 Issued on:

3rd September 2015

Report by:



C. Johnson
Staff Engineer
Building and Life Safety Technologies

Reviewed by:



C. W. Miles
Business Manager – Europe & Latin America
Building and Life Safety Technologies

For and on behalf of UL International (UK) Ltd.

ANNEX A – Resistance to Fire Classification – Graft FR Board

A.1 Rigid wall constructions according to 1.2.1 with wall thickness of minimum 150 mm

A.1.1 Cable penetration seal with 2x 60 mm thick Graft FR Board 2-S

Penetration Seal: Cables fitted at any position within the aperture, with 60 mm Graft FR Board 2-S to both sides of the wall.

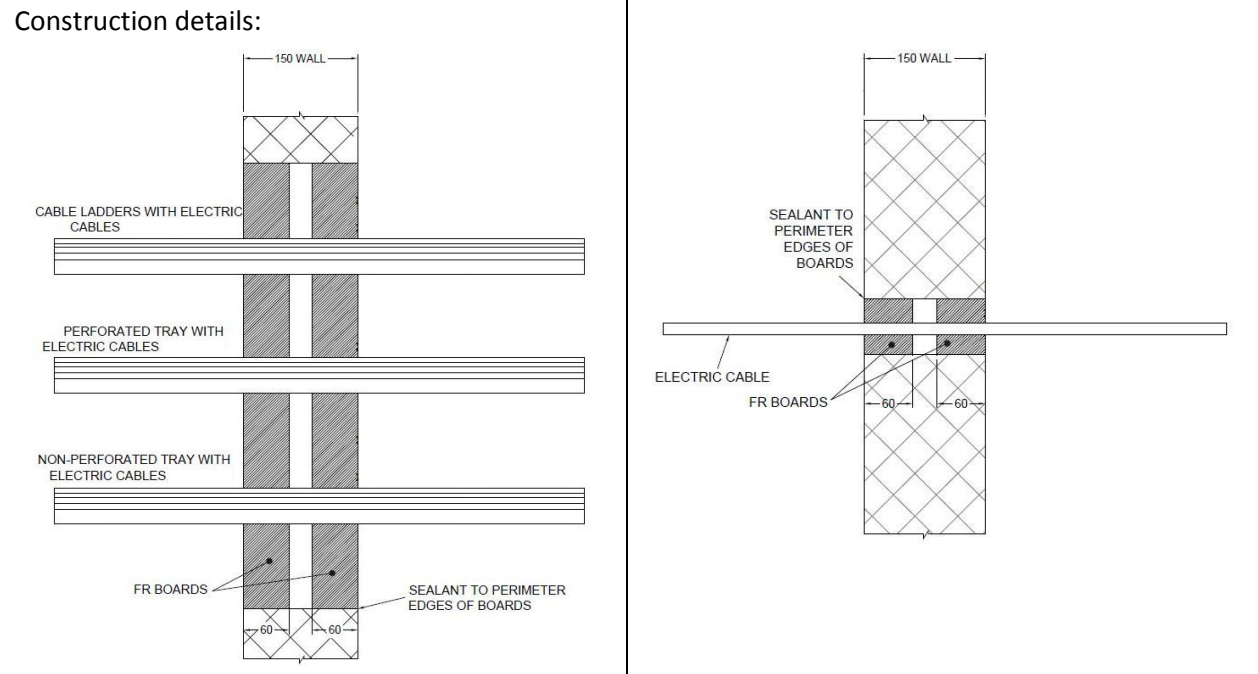

A.1.1.1 Double side penetration seal with cables

Services	Maximum aperture	Classification
None (blank)	2400 mm wide x 1200 mm high	E 240, EI 180
Single electrical cables up to 21 mm \varnothing		
Single or bundled electrical cables up to 21 mm \varnothing , with or without trays		E 240, EI 180
Electrical cables up to 80 mm \varnothing (single, bundled and on trays)		E 180, EI 60
Cables up to 21mm \varnothing in tied bundles up to 100mm \varnothing		E 180, EI 120
Steel cable trays & ladders		E 180, EI 60
PVC conduit up to 16 mm \varnothing		EI 180 C/U, EI 180 C/C

A.1.2 Cable penetration seal with 1x 60 mm thick Graft FR Board 2-S

Penetration Seal: Cables (single) fitted at any position within the aperture, with Graft FR Board 2-S positioned to either face of the wall (or anywhere in between).

Construction details:

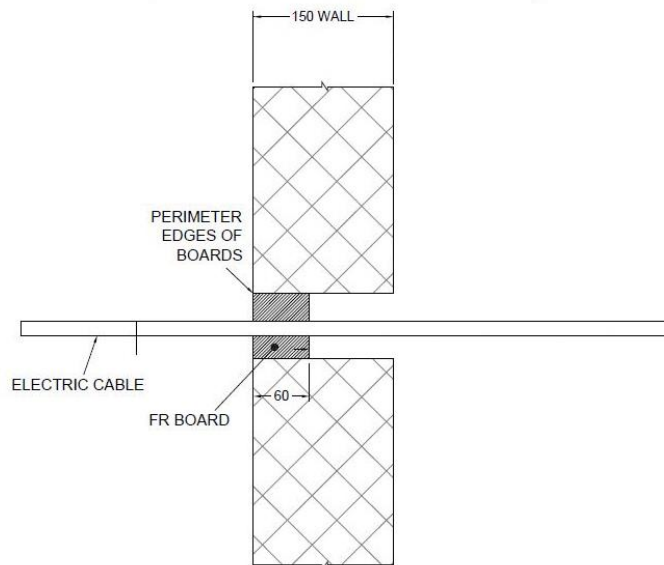

A.1.2.1 Single side penetration seal with cables

Services	Maximum aperture	Classification
None (blank)	2400 mm wide x 1200 mm high	E 240, EI 90
Single electrical cables up to 21 mm \varnothing		
Single A1 cable = 5 x 1.5 mm ² core HD603.3 electrical cable with PVC insulation, PVC sheath and 14 mm diameter	70 x 70 mm	EI 240
Single A2 cable = 5 x 1.5 mm ² core HD22.4 electrical cable with EPR insulation, PO sheath and 11.2-14.4 mm diameter		
Single A3 cable = 5 x 1.5 mm ² core HD604.5 electrical cable with XLPE insulation, EVA sheath and 13 mm diameter		

A.1.3 Pipe penetration seal with 2x 60 mm thick Graft FR Board 2-S

Penetration Seal: 1000 mm (min.) LI (Local Interrupted) or CI (Continuous Interrupted) insulated metallic pipes (single) fitted at any position within the aperture, with 60 mm Graft FR Board to both sides of the wall.

Construction details:

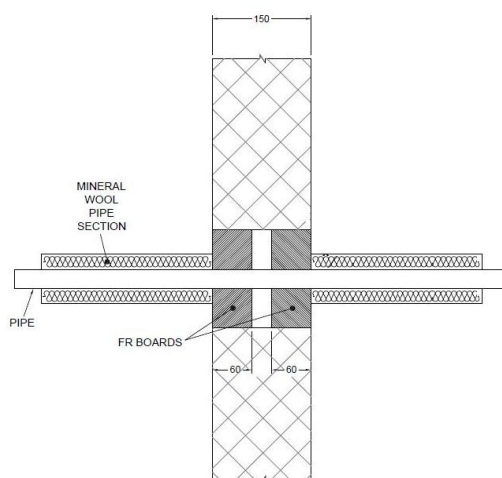

A.1.3.1 Double side penetration seal with pipes

Services	Maximum aperture	Insulation	Classification
Mild or stainless steel pipe			
40 mm diameter/1.5-14.2 mm wall*	100 x 100 mm	20 mm Stone wool insulation 80 kg/m ³	EI 240 C/U
40 mm diameter/1.5-14.2 mm wall*	2400 mm wide x 1200 mm high	30 mm Stone wool insulation 80 kg/m ³	E 240 C/U, EI 180 C/U
40 mm diameter/1.5-14.2 mm wall*			
50 mm diameter/1.7-14.2 mm wall*			
60 mm diameter/1.9-14.2 mm wall*			
75 mm diameter/2.2-14.2 mm wall*			
90 mm diameter/2.5-14.2 mm wall*			
100 mm diameter/2.7-14.2 mm wall*			
115 mm diameter/3-14.2 mm wall*			
140 mm diameter/3.5-14.2 mm wall*			
165 mm diameter/ 3.9-14.2 mm wall*			
180 mm diameter/ 4.2-14.2 mm wall*			
200 mm diameter/ 4.6-14.2 mm wall*			
219 mm diameter/ 5.0-14.2 mm wall*			
			E 240 C/U, EI 90 C/U

* Typical pipe diameters shown, see below graph for intermediate sizes

Services	Maximum aperture	Insulation	Classification
Alupex composite			
16 mm diameter/2.25 mm wall	75 x 75 mm	20 mm Stone wool insulation 80 kg/m ³	EI 240 U/C
16 mm diameter/2.25 mm wall	2400 x 1200 mm		E 240 U/C EI 180 U/C

Pipe diameter vs Wall thickness

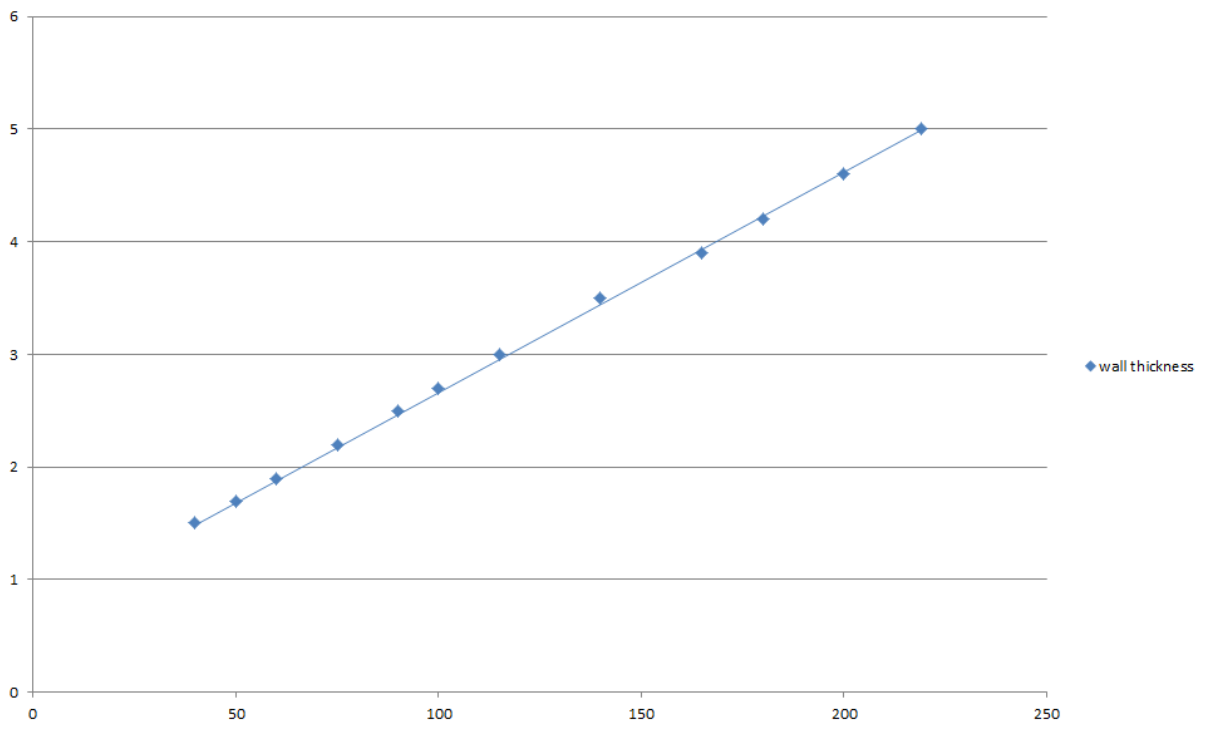

A.1.4 Pipe penetration seal with 1x 60 mm thick Graft FR Board 2-S

Penetration Seal: 1000 mm (min.)* LI (Local Interrupted) or CI (Continuous Interrupted) insulated metallic and composite pipes (single) fitted at any position within the aperture, with 60 mm Graft FR Board to one side of the wall.

Construction details:

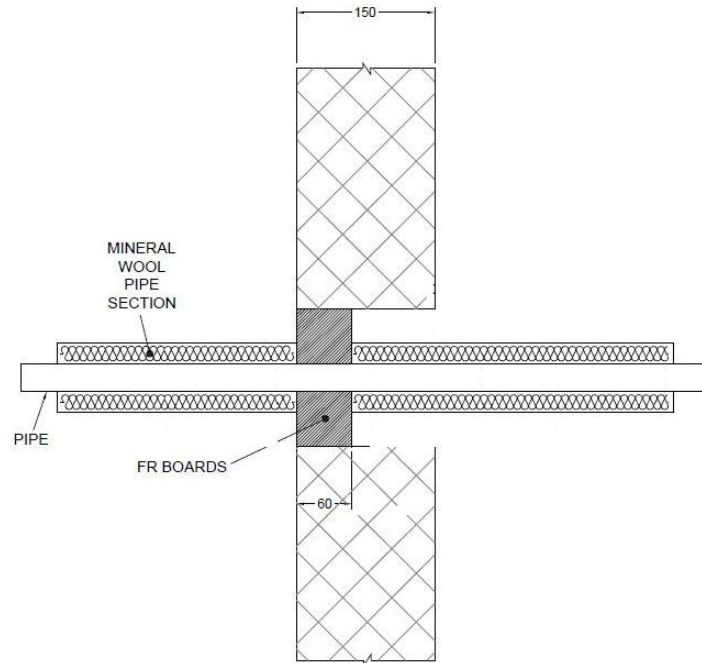

* 600 mm long insulation required for Alupex pipes

A.1.4.1 Single side penetration seal with pipes

Services	Maximum Aperture	Insulation	Classification
Up to 12 mm diameter Copper pipe 0.9-14.2 mm wall	70 x 70 mm	20 mm Stone wool insulation 80 kg/m ³	EI 240 C/U
Up to 54 mm diameter Copper pipe 0.9-14.2 mm wall	115 x 115 mm		E 240 C/U, EI 120 C/U
75 mm diameter Alupex composite pipe 7.5 mm diameter	200 x 200 mm	30 mm Stone wool insulation 80 kg/m ³	EI 120 C/C
Up to 54 mm diameter Copper pipe 0.9-14.2 mm wall	2400 mm wide x 1200 mm high	20 mm Stone wool insulation 80 kg/m ³	E 240 C/U, EI 90 C/U
Up to 75 mm diameter Alupex composite pipe 7.5 mm diameter		30 mm Stone wool insulation 80 kg/m ³	E 120 C/C, EI 90 C/C

Services	Maximum Aperture	Insulation	Classification
Mild or stainless steel pipe			
40 mm diameter/1.5-14.2 mm wall*	280 x 280 mm	20 mm Stone wool insulation 80 kg/m ³	EI 240 C/U
40 mm diameter/1.5-14.2 mm wall*		30 mm Stone wool insulation 80 kg/m ³	
50 mm diameter/1.7-14.2 mm wall*			
60 mm diameter/1.9-14.2 mm wall*			
75 mm diameter/2.2-14.2 mm wall*			
90 mm diameter/2.5-14.2 mm wall*			
100 mm diameter/2.7-14.2 mm wall*			
115 mm diameter/3-14.2 mm wall*			
140 mm diameter/3.5-14.2 mm wall*			
165 mm diameter/ 3.9-14.2 mm wall*			
180 mm diameter/ 4.2-14.2 mm wall*			
200 mm diameter/ 4.6-14.2 mm wall*			
219 mm diameter/ 5.0-14.2 mm wall*			
40 mm diameter/1.5-14.2 mm wall*	2400 mm wide by 1200 mm high	20 mm Stone wool insulation 80 kg/m ³	E 240 C/U, EI 90 C/U
50 mm diameter/1.7-14.2 mm wall*		30 mm Stone wool insulation 80 kg/m ³	
60 mm diameter/1.9-14.2 mm wall*			
75 mm diameter/2.2-14.2 mm wall*			
90 mm diameter/2.5-14.2 mm wall*			
100 mm diameter/2.7-14.2 mm wall*			
115 mm diameter/3-14.2 mm wall*			
140 mm diameter/3.5-14.2 mm wall*			
165 mm diameter/ 3.9-14.2 mm wall*			
180 mm diameter/ 4.2-14.2 mm wall*			
200 mm diameter/ 4.6-14.2 mm wall*			
219 mm diameter/ 5.0-14.2 mm wall*			

* Typical pipe diameters shown, see below graph for intermediate sizes

Pipe diameter vs Wall thickness

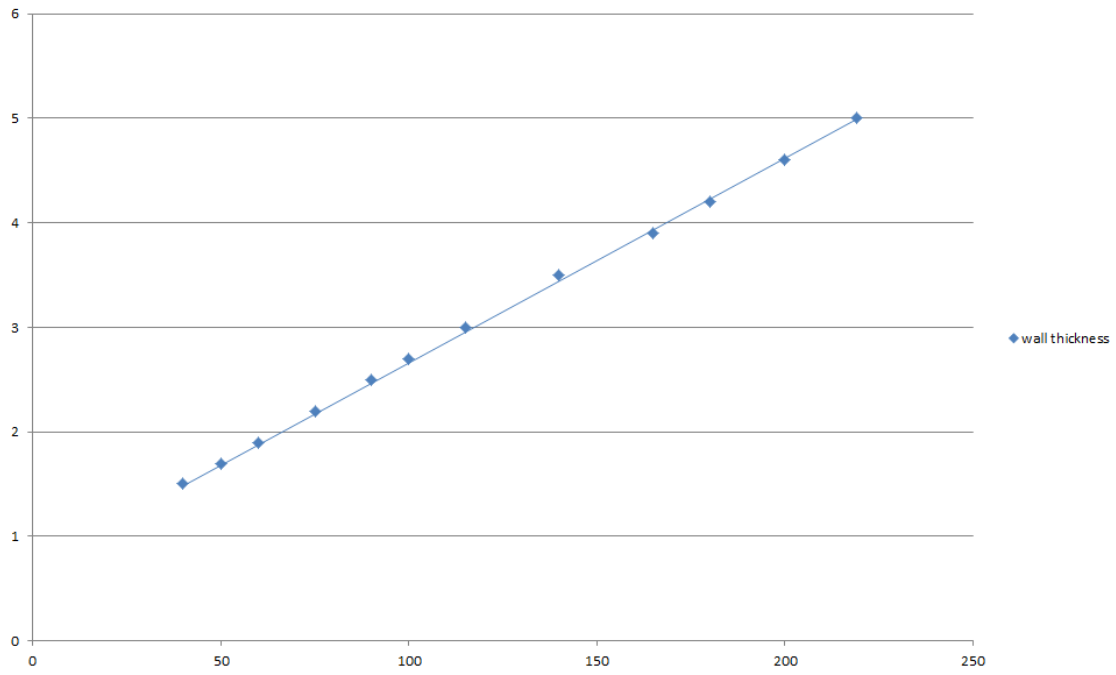

A.1.5 Pipe penetration seal with 1x Graft FR Board 2-S

Penetration Seal: CS (Continuous Sustained) insulated metallic pipes fitted at any position within the aperture, with 60 mm Graft FR Board 2-S to either side of the wall (or anywhere in between). Graft FR Pipe Wraps are required to be fitted around combustible pipe insulation. Maximum aperture size 2400 mm x 1200 mm

Construction details:

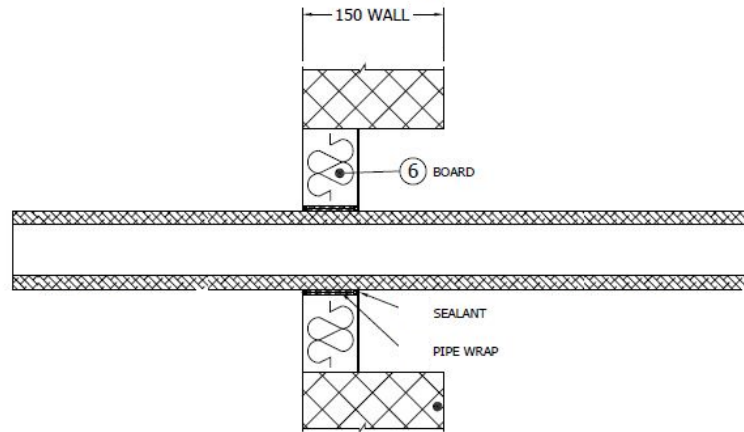

A.1.5.1 Single side penetration seal with pipes

Services	Wrap	Insulation	Classification
Mild or stainless steel pipe			
165 mm diameter/ 4.5-14.2 mm wall	50 x 1.8 mm GRAFT FR PIPE WRAP fitted centrally	9-25 mm Kaiflex ST/KK insulation	E 120 U/C, E 120 C/U, E 120 C/C, EI 45 U/C, EI 45 C/U, EI 45 C/C
219 mm diameter/ 5-14.2 mm wall	Not required	30 mm stone wool 80 kg/m ³	E 240 U/C, E 240 C/U, E 240 C/C, EI 60 U/C, EI 60 C/U, EI 60 C/C

A.1.6 Graft FR Board 60 mm 2-S penetration seal (protruding) blank and with cables, in rigid wall min. 150 mm thick

Penetration Seal: Cables fitted at any position within the aperture, with 60 mm Graft FR Board 2-S to both sides of the wall. Boards to be separated by minimum 90 mm.

Construction details:

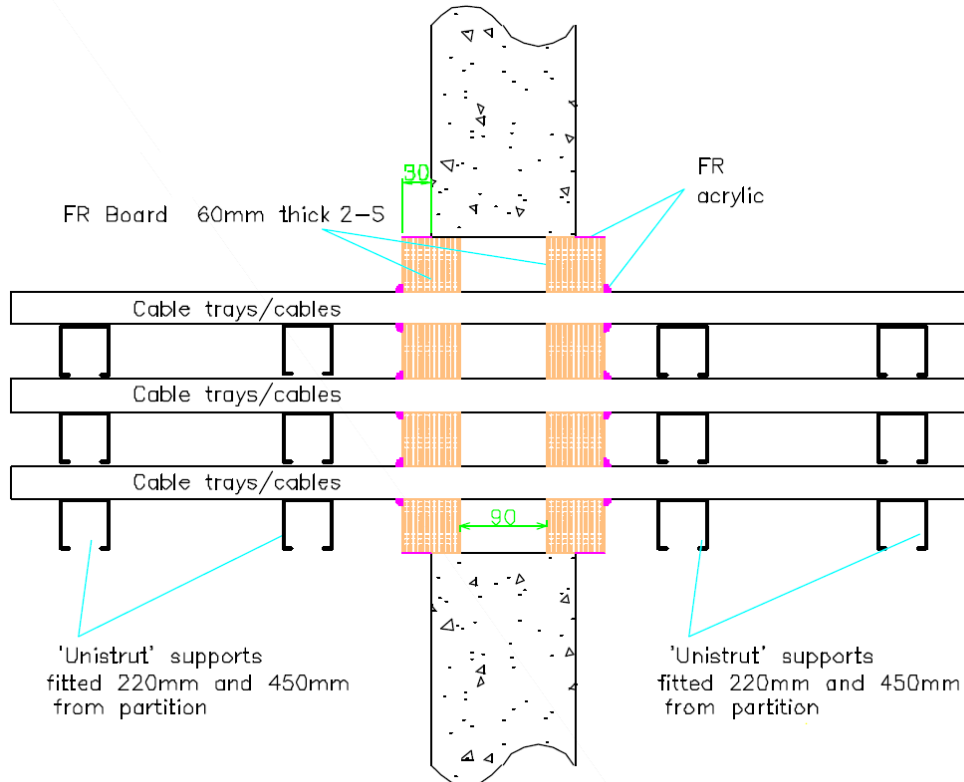

A.1.6.1 Two side penetration seal with cables

Services	Maximum aperture	Classification
None (blank)	600 mm wide x 600 mm high	E 240, EI 180
Single or bundled electrical cables up to 21 mm \varnothing , with or without trays		E 240, EI 120
Electrical cables up to 80 mm \varnothing (single, bundled and on trays)		E 240, EI 60
Cables up to 21mm \varnothing in tied bundles up to 100mm \varnothing		EI 240
Steel cable trays & ladders		E 240, EI 180
Non-Sheathed wires up to 17 mm \varnothing		E 240, EI 180
Non-Sheathed wires up to 24 mm \varnothing		E 240, EI 90

A.1.7 FR Board 60 mm 2-S penetration seal (pattress) blank and with cables, in rigid wall min. 150 mm thick

Penetration Seal: Cables fitted at any position within the aperture, with 60 mm Graft FR Board 2-S to both sides of the wall. Boards to be pattress fixed with 100 mm steel screws and penny washers at 350 mm centres and with a minimum 50 mm overlap around the opening.

Construction details:

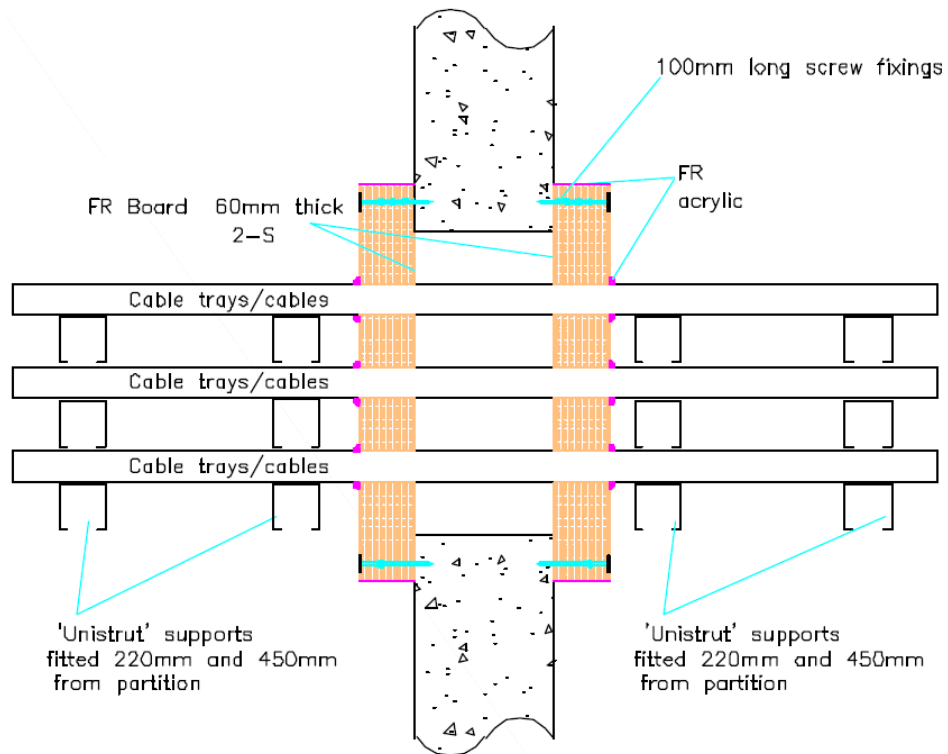

A.1.7.1 Two side penetration seal with cables

Services	Maximum aperture	Classification
None (blank)	600 mm wide x 600 mm high	E 240, EI 180
Single or bundled electrical cables up to 50 mm Ø, with or without trays		E 240, EI 90
Single or bundled electrical cables up to 80 mm Ø (single, bundled and on trays)		E 240, EI 60
Cables up to 21mm Ø in tied bundles up to 100mm Ø		EI 240
Steel cable trays & ladders		E 240, EI 180
Non-Sheathed wires up to 24 mm Ø		E 240 , EI 120

A.2 Rigid floor constructions according to 1.2.1 with floor thickness of minimum 150 mm

A.2.1 Cable penetration seal with 2x Graft FR Board 2-S

Penetration Seal: Cables fitted at any position within the aperture, with 60 mm Graft FR Board 2-S to both sides of the floor.

Construction details:

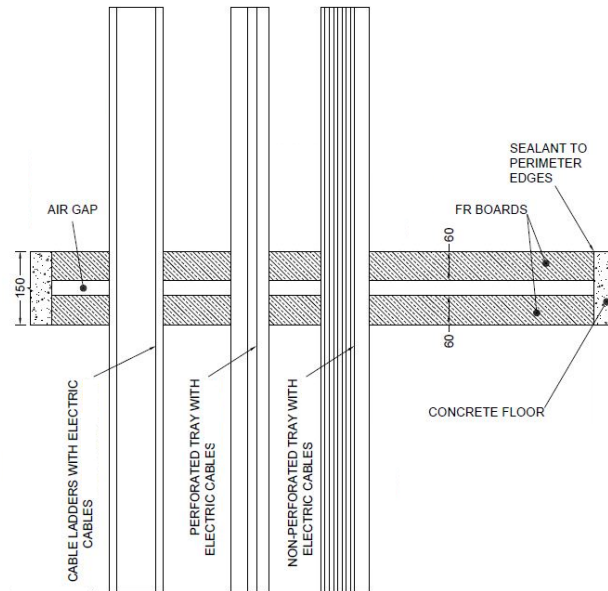

A.2.1.1 Double side penetration seal with cables

Services	Maximum aperture	Classification
None (blank)	2400 mm x 1200 mm	E 180, EI 120
Electrical cables up to 21 mm \varnothing (single, bundled and on trays)		EI 120
Electrical cables up to 80 mm \varnothing (single, bundled and on trays)		E 120, EI 60
Cables up to 21mm \varnothing in tied bundles up to 100mm \varnothing		EI 120
Steel cable trays & ladders		E 120, EI 60
Non-sheathed wires up to 24 mm \varnothing		E 180, EI 45
PVC conduit up to 16 mm \varnothing		E 120 C/U, E 120 C/C, EI 90 C/U, EI 90 C/C

A.2.2 Cable penetration seal with 1x Graft FR Board 2-S

Penetration Seal: Cables fitted at any position within the aperture, with Graft FR Board 2-S positioned to either face of the floor (or anywhere in between).

Construction details:

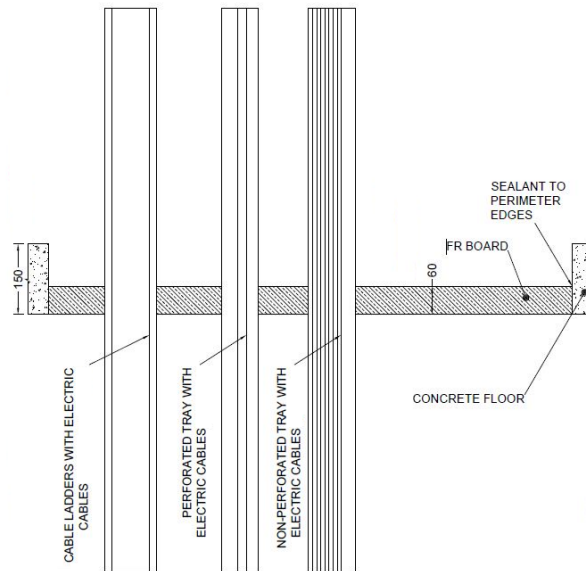

A.2.2.1 Single side penetration seal with cables

Services	Maximum aperture	Classification
None (blank)	2400 mm x 1200 mm	E 120, EI 90
Single* electrical cables up to 21 mm \varnothing		E 120, EI 30
Single* electrical cables up to 21 mm \varnothing	600 mm x 1200 mm	E 240, EI 30
Electrical cables up to 21 mm \varnothing (single, bundled and on trays)	2400 mm x 1200 mm	E 90, EI 45
Electrical cables up to 80 mm \varnothing (single, bundled and on trays)		E 90, EI 30
Cables up to 21mm \varnothing in tied bundles up to 100mm \varnothing		EI 45
Steel cable trays & ladders		EI 45
Non-sheathed wires up to 17 mm \varnothing		E 45, EI 30
Non-sheathed wires up to 24 mm \varnothing		E 45, EI 20
PVC conduit up to 16 mm \varnothing		EI 45 C/U, EI 45 C/C
Steel or copper conduit up to 16 mm \varnothing		E 45 C/U, EI 15 C/U

A.2.3 Pipe penetration seal with 2x Graft FR Board 2-S

Penetration Seal: 1000 mm (min.) LI (Local Interrupted) or CI (Continuous Interrupted) insulated metallic pipes (single) fitted at any position within the aperture, with 2 layers of 60 mm Graft FR Board 2-S together within the floor.

Construction details:

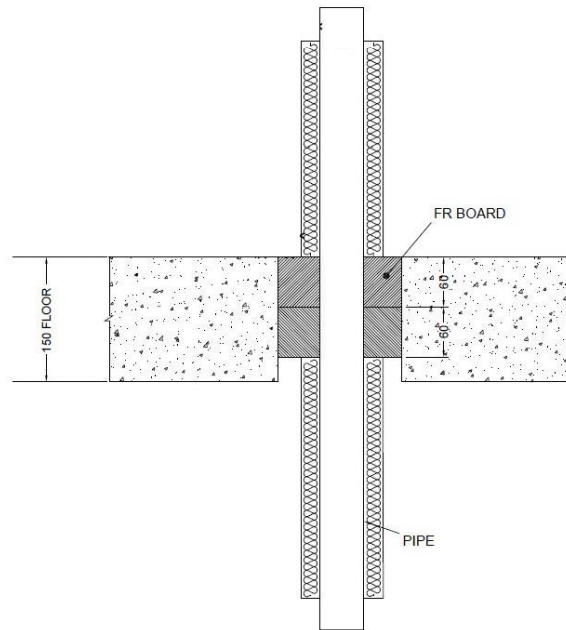

A.2.3.1 Two layer penetration seal with pipes

Services	Maximum aperture	Insulation	Classification
Mild or stainless steel pipe			
40 mm diameter/1.5-14.2 mm wall*	280 x 280 mm	20 mm Stone wool insulation 80 kg/m ³	EI 240 C/U
40 mm diameter/1.5-14.2 mm wall*	2400 x 1200 mm	30 mm Stone wool insulation 80 kg/m ³	E 180 C/U, EI 120 C/U
40 mm diameter/1.5-14.2 mm wall*			
50 mm diameter/1.7-14.2 mm wall*			
60 mm diameter/1.8-14.2 mm wall*			
75 mm diameter/2.1-14.2 mm wall*			
90 mm diameter/2.3-14.2 mm wall*			
100 mm diameter/2.5-14.2 mm wall*			
115 mm diameter/2.8-14.2 mm wall*			
140 mm diameter/3.2-14.2 mm wall*			
165 mm diameter/ 3.6-14.2 mm wall*			
180 mm diameter/ 3.9-14.2 mm wall*			
200 mm diameter/ 4.2-14.2 mm wall*			
219 mm diameter/ 4.5-14.2 mm wall*			
			E 180 C/U, EI 60 C/U

* Typical pipe diameters shown, see below graph for intermediate sizes

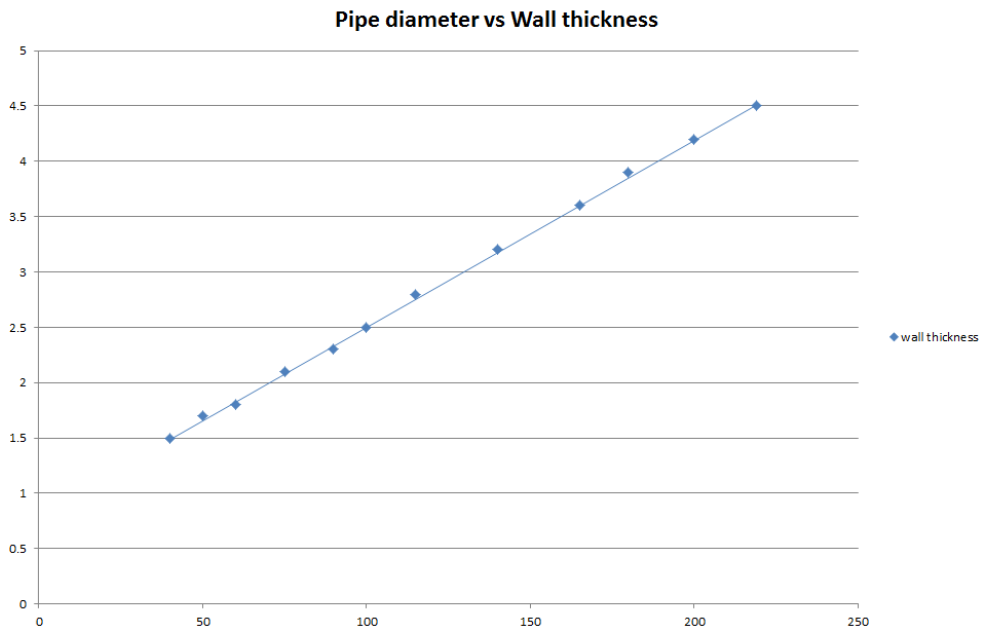

A.2.4 Pipe penetration seal with 1x Graft FR Board 2-S

Penetration Seal: 1000 mm (min.)* LI (Local Interrupted) or CI (Continuous Interrupted) insulated metallic pipes (single) fitted at any position within the aperture, with 60 mm Graft FR Board 2-S to either side of the floor (or anywhere in between).

Construction details:

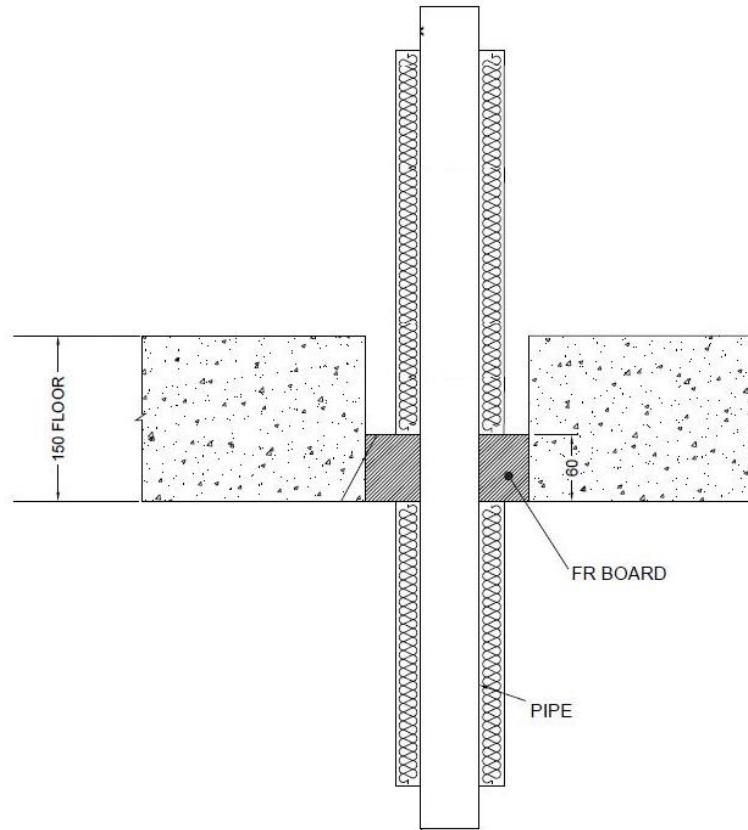

A.2.4.1 Single side penetration seal with pipes

Services	Maximum Aperture	Insulation	Classification
Up to 12 mm diameter Copper pipe 0.9-14.2 mm wall	70 x 70 mm	20 mm Stone wool insulation 80 kg/m ³	E 240 C/U, EI 45 C/U
Up to 54 mm diameter Copper pipe 0.9-14.2 mm wall	115 x 115 mm		E 240 C/U
	2400 mm x 1200 mm		E 120 C/U
114 mm diameter mild or stainless steel pipe 11-14.2 mm wall	600 x 1200	None	E 240 C/C, EI 20 C/C
	2400 mm x 1200 mm		E 120 C/C, EI 20 C/C

Services	Maximum Aperture	Insulation	Classification
Mild or stainless steel pipe			
40 mm diameter/1.5-14.2 mm wall*	600 x 1200 mm	20 mm Stone wool insulation 80 kg/m ³	E 240 C/U, EI 60 C/U
40 mm diameter/1.5-14.2 mm wall*		30 mm Stone wool insulation 80 kg/m ³	E 240 C/U, EI 90 C/U
50 mm diameter/1.7-14.2 mm wall*			
60 mm diameter/1.8-14.2 mm wall*			
75 mm diameter/2.1-14.2 mm wall*			
90 mm diameter/2.3-14.2 mm wall*			
100 mm diameter/2.5-14.2 mm wall*			
115 mm diameter/2.8-14.2 mm wall*			
140 mm diameter/3.2-14.2 mm wall*			
165 mm diameter/ 3.6-14.2 mm wall*			
180 mm diameter/ 3.9-14.2 mm wall*			
200 mm diameter/ 4.2-14.2 mm wall*			
219 mm diameter/ 4.5-14.2 mm wall*			
40 mm diameter/1.5-14.2 mm wall*	2400 mm wide by 1200 mm high	20 mm Stone wool insulation 80 kg/m ³	E 120 C/U, EI 60 C/U
40 mm diameter/1.5-14.2 mm wall*		30 mm Stone wool insulation 80 kg/m ³	E 120 C/U, EI 90 C/U
50 mm diameter/1.7-14.2 mm wall*			
60 mm diameter/1.8-14.2 mm wall*			
75 mm diameter/2.1-14.2 mm wall*			
90 mm diameter/2.3-14.2 mm wall*			
100 mm diameter/2.5-14.2 mm wall*			
115 mm diameter/2.8-14.2 mm wall*			
140 mm diameter/3.2-14.2 mm wall*			
165 mm diameter/ 3.6-14.2 mm wall*			
180 mm diameter/ 3.9-14.2 mm wall*			
200 mm diameter/ 4.2-14.2 mm wall*			
219 mm diameter/ 4.5-14.2 mm wall*			

* Typical pipe diameters shown, see below graph for intermediate sizes

Pipe diameter vs Wall thickness

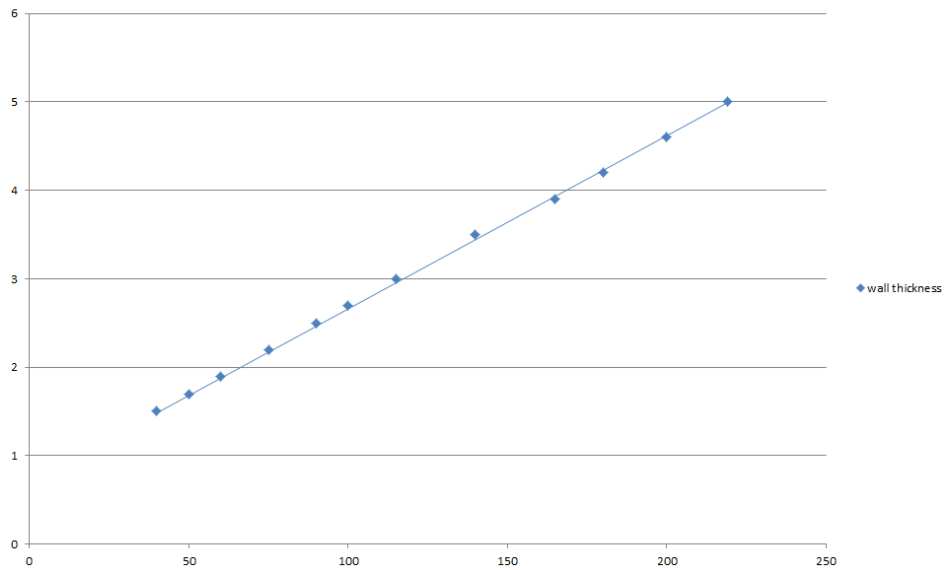

Services	Maximum Aperture	Insulation (minimum)	Classification
Geberit Mepla MLC (PE-Xb/Aluminium/PE-HD pipe)			
16 mm diameter/2.25 mm wall	75 x 75 mm		E 240 C/C, EI 180 C/C
16 mm diameter/2.25 mm wall	600 x 1200 mm	500 mm long, 20 mm Stone wool insulation 80 kg/m ³	E 240 C/C, EI 90 C/C
20 mm diameter/2.5 mm wall			
26 mm diameter/3 mm wall			
32 mm diameter/3 mm wall			
40 mm diameter/3.5 mm wall			
50 mm diameter/4 mm wall			
63 mm diameter/4.5 mm wall			
75 mm diameter/4.7 mm wall			
16 mm diameter/2.25 mm wall	2400 mm x 1200 mm	500 mm long, 20 mm Stone wool insulation 80 kg/m ³	E 120 C/C, EI 90 C/C
20 mm diameter/2.5 mm wall			
26 mm diameter/3 mm wall			
32 mm diameter/3 mm wall			
40 mm diameter/3.5 mm wall			
50 mm diameter/4 mm wall			
63 mm diameter/4.5 mm wall			
75 mm diameter/4.7 mm wall			

A.2.5 Pipe penetration seal with 1x Graft FR Board 2-S

Penetration Seal: Combustible pipes fitted at any position within the aperture, with 50 mm Graft FR Board 2-S at mid-depth of the floor. Graft FR Pipe Wraps are required to be fitted around combustible pipe insulation. Maximum aperture size 400 mm x 400 mm

Construction details:

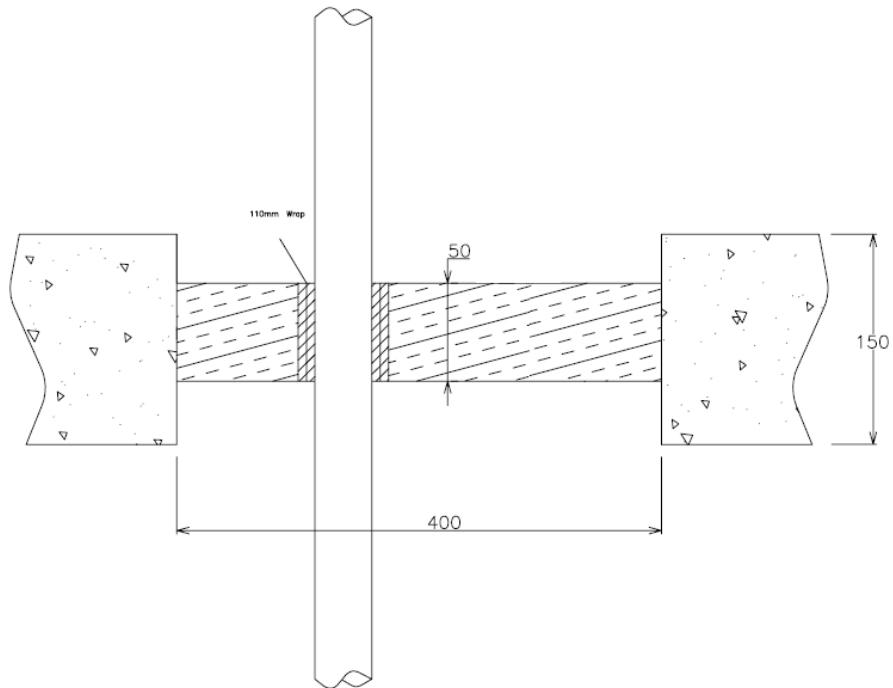

A.2.5.1 Central penetration seal with pipes

Services	Wrap	Classification
PVC-U pipe according to EN 1329-1, EN 1452-1 and EN 1453-1* 110 mm diameter/ 3.4mm wall	50 x 3.6 mm GRAFT FR PIPE WRAP	EI 90 U/C, EI 90 C/C

A.2.6 Pipe penetration seal with 1x Graft FR Board 2-S

Penetration Seal: CS (Continuous Sustained) insulated metallic pipes fitted at any position within the aperture, with 60 mm Graft FR Board 2-S to either side of the floor (or anywhere in between). Graft FR Pipe Wraps are required to be fitted around combustible pipe insulation. Maximum aperture size 2400 mm x 1200 mm

Construction details:

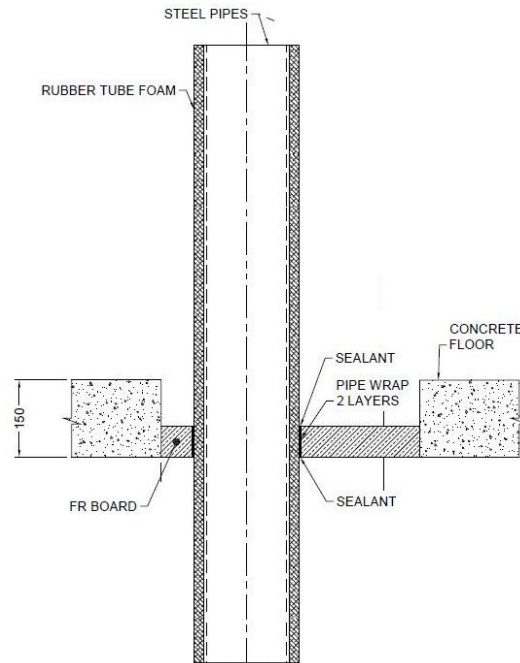

A.2.6.1 Single side penetration seal with pipes

Services	Wrap	Insulation	Classification
Mild or stainless steel pipe			
165 mm diameter/ 4.5-14.2 mm wall	50 x 3.6 mm GRAFT FR PIPE WRAP fitted at bottom of seal	13 mm Kaiflex ST insulation	E 90 C/U, EI 45 C/U
		19 mm Kaiflex ST insulation	EI 90 C/U
	Not required	25-40 mm stone wool 80 kg/m ³	E 90 C/U, EI 60 C/U

A.2.7 Pipe penetration seal with 2x Graft FR Board 2-S

Penetration Seal: CS (Continuous Sustained) insulated metallic pipes fitted at any position within the aperture, with 60 mm Graft FR Board 2-S to both sides of the floor. Graft FR Pipe Wraps are required to be fitted around combustible pipe insulation at the soffit. Maximum aperture size 2400 mm x 1200 mm

Construction details:

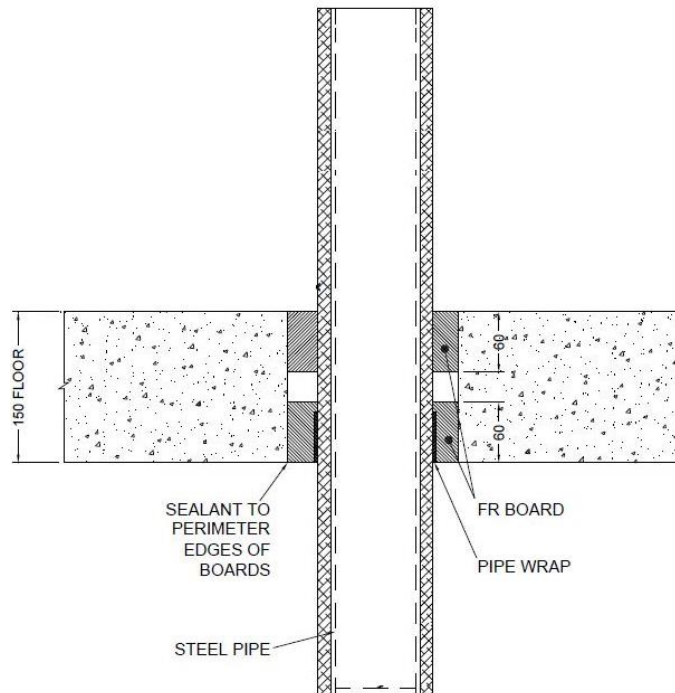

A.2.7.1 Double side penetration seal with pipes

Services	Wrap	Insulation	Classification
Mild or stainless steel pipe			
40 mm diameter/ 1-14.2 mm wall	50 x 1.8 mm GRAFT FR PIPE WRAP	13 mm Kaiflex ST insulation	E 180 C/U, EI 120 C/U

A.2.8 Pipe penetration seal with 2x Graft FR Board 2-S (back to back)

Penetration Seal: CS (Continuous Sustained) insulated metallic and composite pipes fitted at any position within the aperture, with two layers of 60 mm Graft FR Board 1-S installed together to either side of the floor (or anywhere in between). Graft FR Pipe Wraps are required to be fitted around combustible pipe insulation at the bottom of the seal. Maximum aperture size 2400 mm x 1200 mm

Construction details:

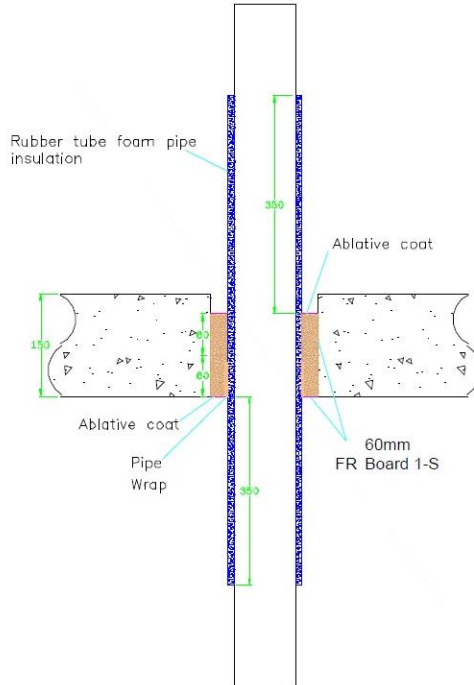

A.2.8.1 Back to back penetration seal with pipes

Services	Wrap	Insulation	Classification
Copper pipe	50 x 3.6 mm GRAFT FR PIPE WRAP fitted to both sides of the seal	9-13 mm Kaiflex ST insulation	E240 C/C, EI 60 C/C
12-54 mm diameter/1-1.2 mm wall		13-25 mm Kaiflex ST insulation	E 180 C/C, EI 45 C/C
12-54 mm diameter/1-1.2 mm wall			
Geberit Mepla MLC (PE-Xb/Aluminium/PE-HD pipe)			
16 mm diameter/2.25 mm wall	50 x 3.6 mm GRAFT FR PIPE WRAP fitted to both sides of the seal	9 mm Kaiflex ST insulation	EI 120 C/C
20 mm diameter/2.5 mm wall			
26 mm diameter/3 mm wall			
32 mm diameter/3 mm wall			
40 mm diameter/3.5 mm wall			
50 mm diameter/4 mm wall			
63 mm diameter/4.5 mm wall			
75 mm diameter/4.7 mm wall			
16 mm diameter/2.25 mm wall		13-25 mm Kaiflex ST insulation	E 60 C/C, EI 45 C/C
20 mm diameter/2.5 mm wall			
26 mm diameter/3 mm wall			
32 mm diameter/3 mm wall			
40 mm diameter/3.5 mm wall			
50 mm diameter/4 mm wall			
63 mm diameter/4.5 mm wall			
75 mm diameter/4.7 mm wall			

A.3 Flexible wall constructions according to 1.2.1 with wall thickness of minimum 100 mm

A.3.1 Cable penetration seal with 2x Graft FR Board 1-S

Penetration Seal: Cables fitted at any position within the aperture, with 50 mm Graft FR Board 1-S to both sides of the wall.

Construction details:

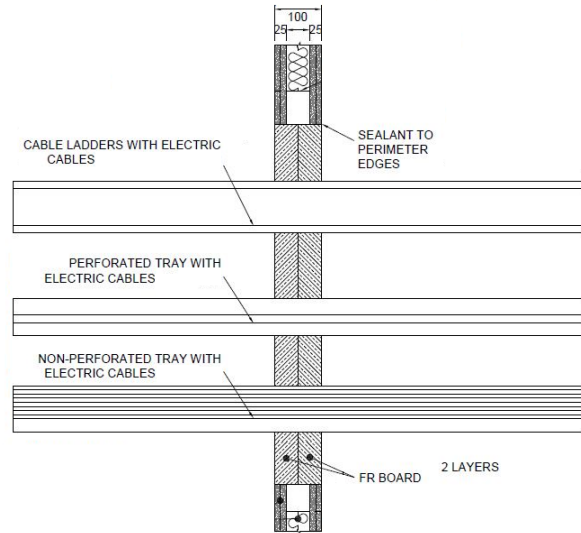
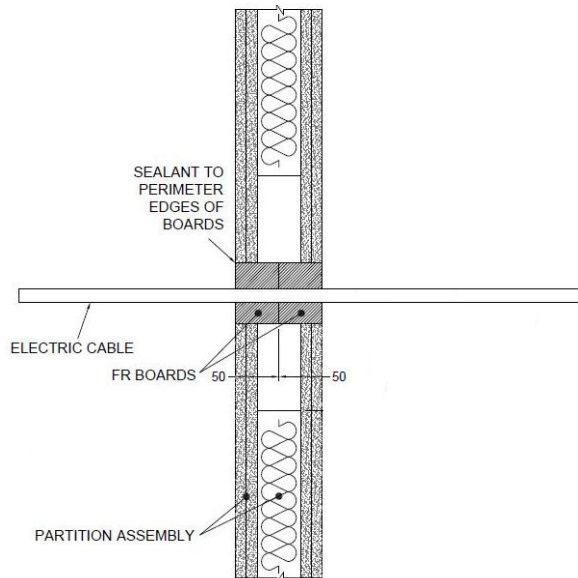

Note: Insulated metal pipes may also be included within the same seal as cables subject to minimum 100 mm separation. See separate classification for pipes.

A.3.1.1 Double side penetration seal with cables

Services	Maximum aperture	Classification
None (blank)	2400 mm wide x 1200 mm high	EI 120
Single electrical cables up to 21 mm \varnothing		E 120, EI 60
Electrical cables up to 80 mm \varnothing (single, bundled and on trays)		EI 60
Cables up to 21mm \varnothing in tied bundles up to 100mm \varnothing		
Steel cable trays & ladders		EI 60 C/U
Steel conduit up to 16 mm \varnothing		E 60 C/U, EI 45 C/U
copper conduit up to 16 mm \varnothing		E 60, EI 30
Unsheathed wires up to 24 mm \varnothing		EI 60 C/U, EI 60 C/C
PVC conduit up to 16 mm \varnothing		

A.3.2 Pipe penetration seal with 2x Graft FR Board 1-S

Penetration Seal: CS (Continuous Sustained) insulated metallic pipes fitted at any position within the aperture, with 50 mm Graft FR Board 1-S to both sides of the wall. Graft FR Pipe Wraps are required to be fitted around the pipe insulation. Maximum aperture size 2400 mm x 1200 mm.

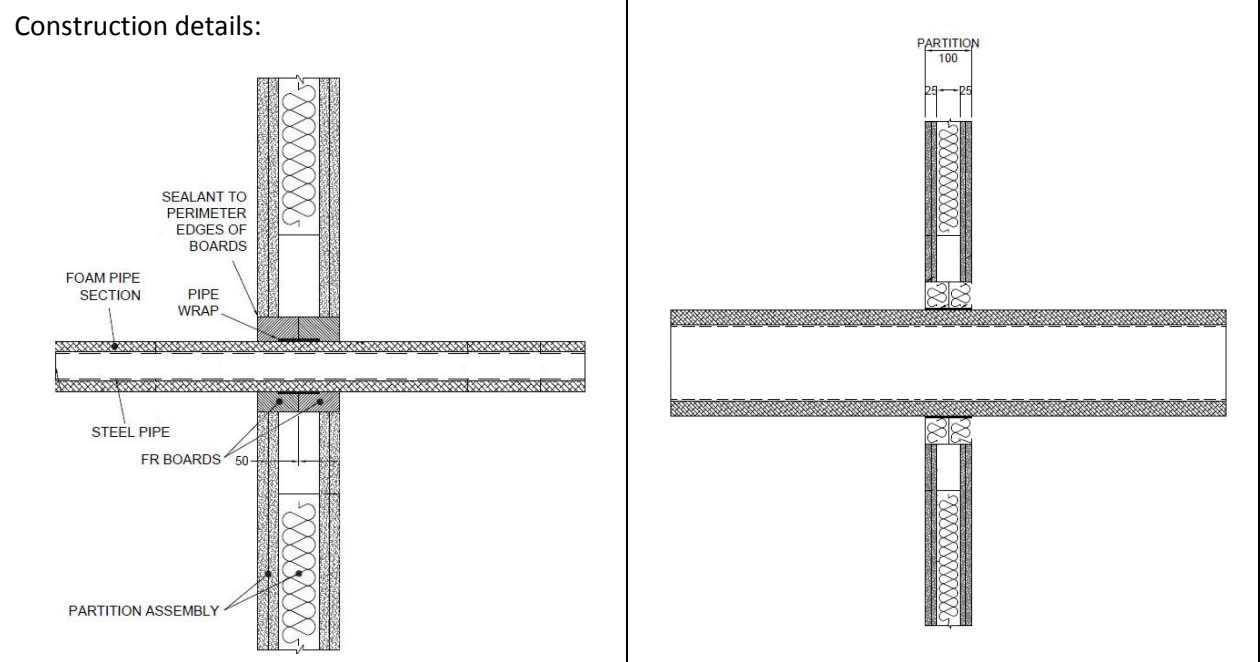

A.3.2.1 Two layer penetration seal with pipes

Services	Wrap	Insulation	Classification
Mild or stainless steel pipe			
40 mm diameter/1-14.2 mm wall	50 x 1.8 mm GRAFT FR PIPE WRAP fitted centrally	13 mm Kaiflex ST insulation	EI 120 U/C, EI 120 U/U, EI 120 C/U, EI 120 C/C
40 mm diameter/1-14.2 mm wall*	2 off 50 x 3.6 mm GRAFT FR PIPE WRAP, one fitted flush to each face of seal	13 - 32mm Kaiflex ST insulation	E 120 U/C, E 120 U/U, E 120 C/U, E 120 C/C, EI 60 U/C, EI 60 U/U, EI 60 C/U, EI 60 C/C
50 mm diameter/1.3-14.2 mm wall*			
60 mm diameter/1.6-14.2 mm wall*			
75 mm diameter/2-14.2 mm wall*			
90 mm diameter/2.4-14.2 mm wall*			
100 mm diameter/2.7-14.2 mm wall*			
115 mm diameter/3.1-14.2 mm wall*			
140 mm diameter/3.8-14.2 mm wall*			
165 mm diameter/ 4.5-14.2 mm wall*			

* Typical pipe diameters shown, see below graph for intermediate sizes

Pipe diameter vs Wall thickness

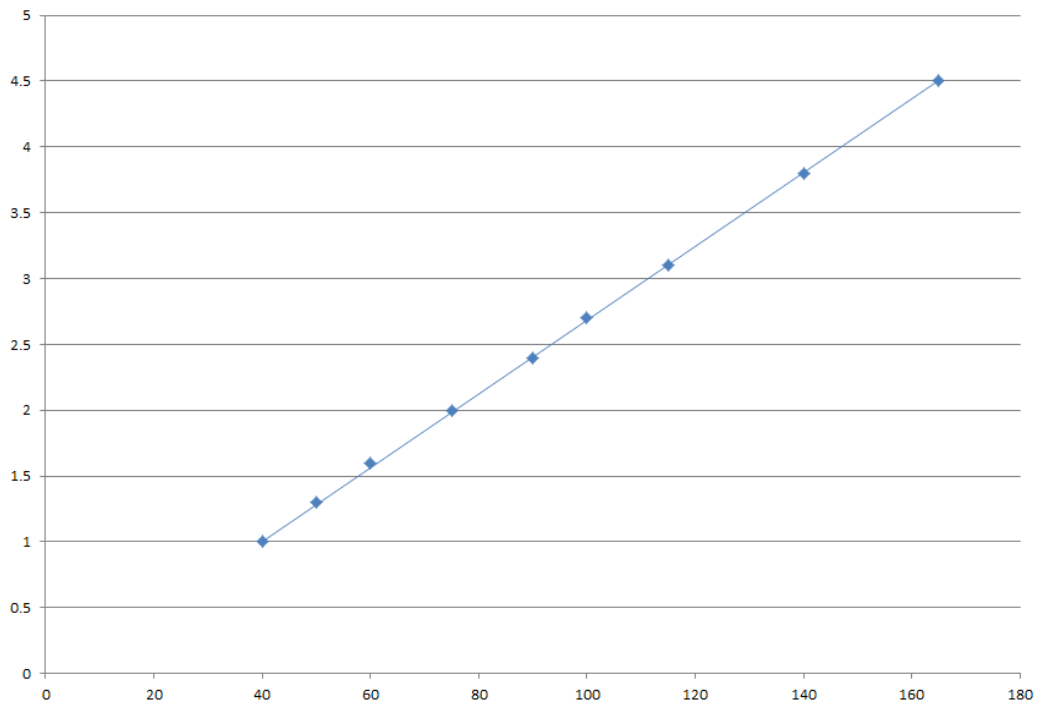

A.3.3 Pipe penetration seal with 2x Graft FR Board 1-S

Penetration Seal: 500 mm (min.)* LI (Local Interrupted) or CI (Continuous Interrupted) insulated or uninsulated metallic and composite pipes (single) fitted at any position within the aperture, with 50 mm Graft FR Board 1-S to both sides of the wall. Maximum aperture size 2400 mm x 1200 mm

Construction details:

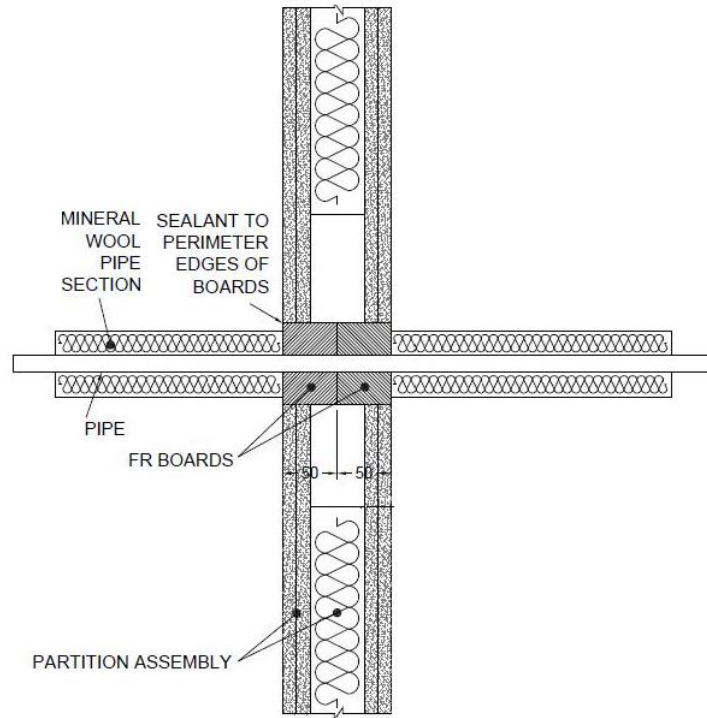

* Minimum 600 mm long insulation required for Alupex pipe.

A.3.3.1 Two layer penetration seal with pipes

Services	Insulation	Classification
Copper pipe up to 54 mm diameter/1-14.2 mm wall	20 mm stone wool 80 kg/m ³	EI 120 C/C
Alupex composite pipe 75 mm diameter/7.5 mm wall	600 mm length of 25 mm Graft Mineral Fibre BIO	EI 60 C/U
Mild or stainless steel pipe 114 mm diameter/11 mm wall	None	E 90 C/U, EI 20 C/U

Services	Insulation	Classification
Mild or stainless steel pipe		
40 mm diameter/1-14.2 mm wall	20 mm stone wool 80 kg/m ³	EI 120 C/U
40 mm diameter/1-14.2 mm wall*	30 mm stone wool 80 kg/m ³	E 120 C/U, EI 90 C/U
50 mm diameter/1.2-14.2 mm wall*		
60 mm diameter/1.4-14.2 mm wall*		
75 mm diameter/1.7-14.2 mm wall*		
90 mm diameter/2-14.2 mm wall*		
100 mm diameter/2.2-14.2 mm wall*		
115 mm diameter/2.5-14.2 mm wall*		
140 mm diameter/3-14.2 mm wall*		
165 mm diameter/3.5-14.2 mm wall*		
180 mm diameter/3.8-14.2 mm wall*		
200 mm diameter/4.2-14.2 mm wall*		
219 mm diameter/4.5-14.2 mm wall*		

* Typical pipe diameters shown, see below graph for intermediate sizes

Pipe diameter vs Wall thickness

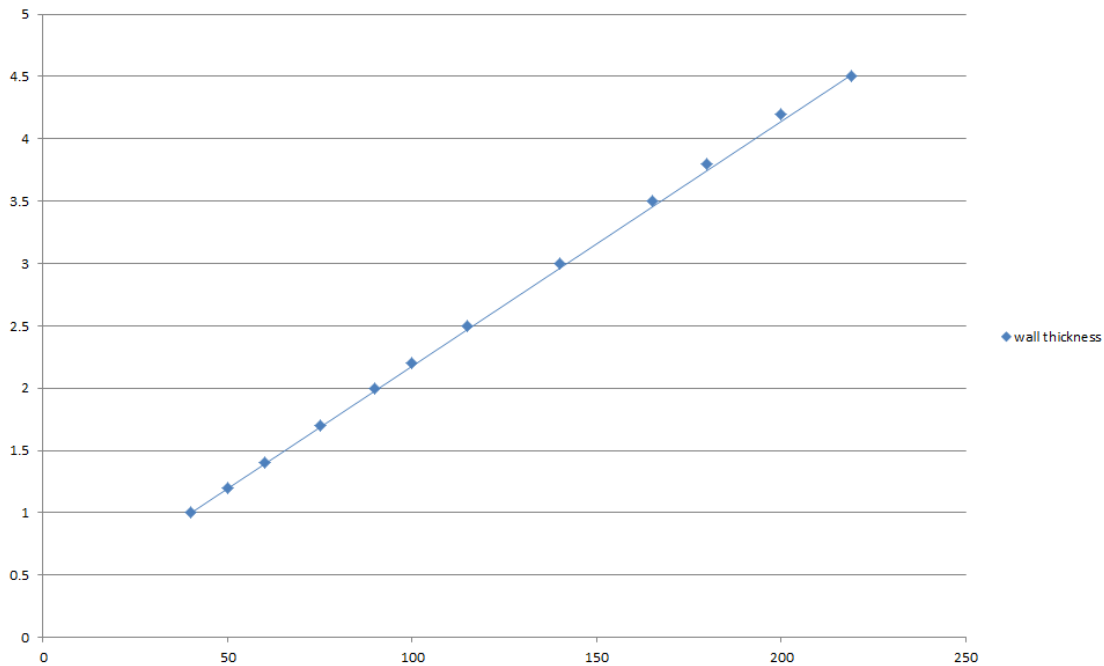

Services	Insulation (minimum)	Classification
Geberit Mepla MLC (PE-Xb/Aluminium/PE-HD) pipe*	20 mm stone wool 80 kg/m ³	EI 120 C/C
16 mm diameter/2.25 mm wall		EI 60 C/C
20 mm diameter/2.5 mm wall		
26 mm diameter/3 mm wall		
32 mm diameter/3 mm wall		
40 mm diameter/3.5 mm wall		
50 mm diameter/4 mm wall		
63 mm diameter/4.5 mm wall		
75 mm diameter/4.7 mm wall		

A.3.4 Pipe penetration seal with 2x Graft FR Board 1-S

Penetration Seal: LS (Local Sustained) or CS (Continuous Sustained) insulated metallic and composite pipes (single) fitted at any position within the aperture, with 50 mm Graft FR Board 1-S to both sides of the wall. Graft FR Pipe Wraps are required to be fitted around the pipe to both sides of the seal. Maximum aperture size 2400 mm x 1200 mm.

Construction details:

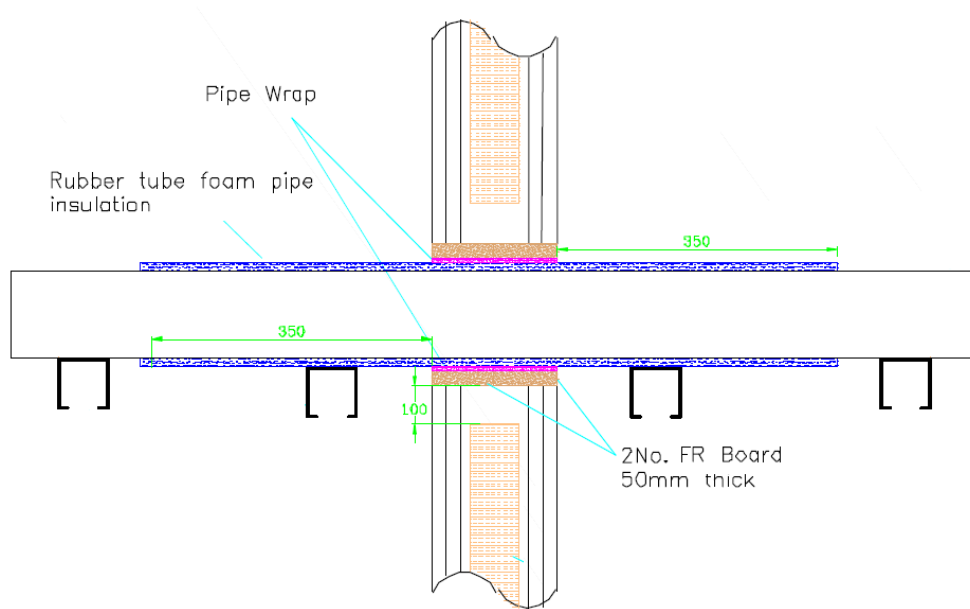

A.3.4.1 Two layer penetration seal with pipes

Services	Wrap	Insulation	Classification
Copper pipe			
12 mm diameter/1 mm wall	50 x 3.6 mm GRAFT FR PIPE WRAP fitted to both sides of the seal	9 mm Kaiflex ST insulation	EI 120 C/C
12-54 mm diameter/1-1.2 mm wall		9-13 mm Kaiflex ST insulation	E 120 C/C, EI 90 C/C
12-54 mm diameter/1-1.2 mm wall		13-25 mm Kaiflex ST insulation	E 120 C/C, EI 60 C/C
Geberit Mepla MLC (PE-Xb/Aluminium/PE-HD pipe)*			
16 mm diameter/2.25 mm wall	50 x 3.6 mm GRAFT FR PIPE WRAP fitted to both sides of the seal	9-25 mm Kaiflex ST insulation	EI 120 C/C
20 mm diameter/2.5 mm wall			
26 mm diameter/3 mm wall			
32 mm diameter/3 mm wall			
40 mm diameter/3.5 mm wall			
50 mm diameter/4 mm wall			
63 mm diameter/4.5 mm wall			
75 mm diameter/4.7 mm wall			

A.3.5 Plastic pipe penetration seal with 2x Graft FR Board 1-S

Penetration Seal: Combustible pipes (single) fitted central within the aperture, with Graft FR Board 1-S to both sides of the wall. Graft FR Pipe Wraps are required to be fitted around the pipe. Maximum aperture size 2400 mm x 1200 mm

Construction details:

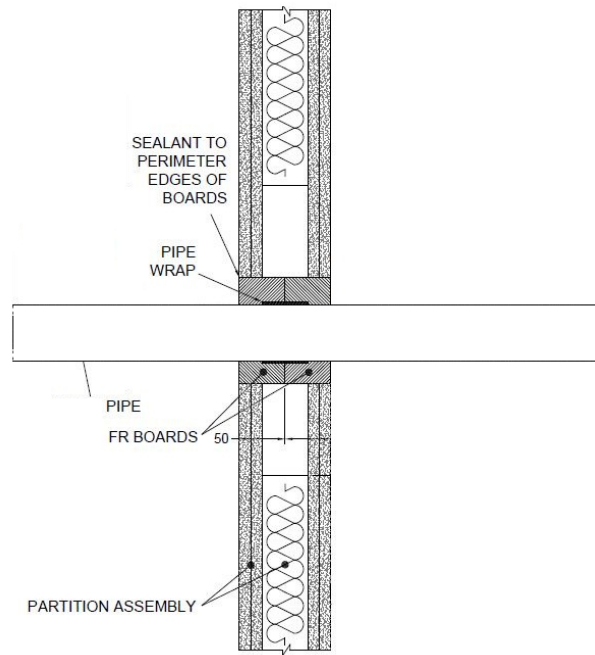

A.3.5.1 Two layer penetration seal with pipes

Services	Pipe Wrap	Classification
PVC-U pipe according to EN 1329-1, EN 1452-1 and EN 1453-1* 315 mm \varnothing /9.2 mm wall	GRAFT FR PIPE WRAP 75 x 18 mm fitted centrally around the pipe	EI 45 C/C

* In Germany the pipes have additionally to comply with DIN 19531-10